

Using the UCC28810EVM-003

User's Guide



Literature Number: SLUU380A
September 2009–Revised November 2009

UCC28810EVM-003 110-W Multiple String LED Driver with Universal Line Input and PFC

1 Introduction

The UCC28810EVM-003 is an 110-W offline AC-to-DC LED current driver with power factor correction. This design utilizes a three stage approach with a universal input boost PFC stage, a low-side buck stage providing a controlled current source and a half-bridge DC transformer stage to provide isolation to four LED strings.

2 Description

This converter was designed to support up to four strings of 15 high brightness LED's in series (58.5 V max per string). The converter will provide 500-mA average current to each string. The design incorporates an interface for microprocessor control to allow for shutdown into a low power mode (<0.5 W) and PWM dimming of the LED's.

The boost, buck and DC half bridge multi-transformer stages are included on a UCC28810EVM-003 single board assembly.

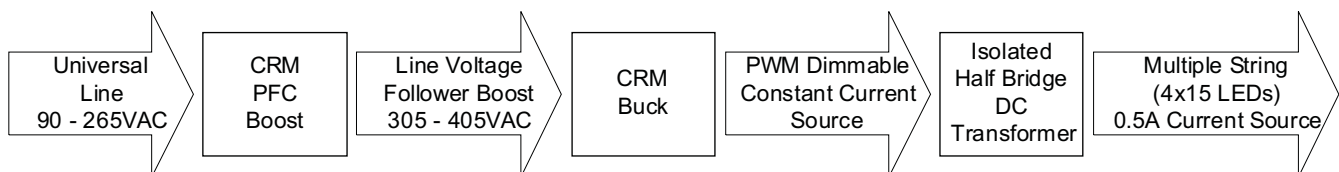

Figure 1. Stages Included in a Single Board Assembly

CAUTION

High voltage levels are present on this reference design whenever it is energized. Proper precautions must be observed whenever working with this module. There is an energy storage capacitor (C17) on this module which must be discharged before the board can be handled. Serious injury can occur if proper safety procedures are not followed.

2.1 Typical Applications

- AC Input General Lighting Applications Using HB LEDs
- Industrial, Commercial and Residential Lighting Fixtures
- Outdoor Lighting: Street, Roadway, Parking, Construction and Ornamental LED Lighting Fixtures
- LCD TV LED Backlighting

2.2 Features

- 90- V_{RMS} to 265- V_{RMS} Operation
- Boost Follower or Fixed Output PFC Stage
- PFC Disable
- Output Current Disable
- External or Internal PWM Dimming
- Output Isolated from Line Input
- Open Circuit Protection (If one LED string fails open the remaining strings stay on.)

3 Electrical Performance Specifications

Table 1. UCC28810EVM-003 Electrical Performance Specifications

PARAMETER	CONDITION	MIN	TYP	MAX	UNITS
$V_{IN, RMS}$		90		265	VRMS
P_F	Dimming 50% to 100%	0.95%	0.98%		
$P_{OUT, LED Driver}$			105	117	W
$I_{AVG, LED}$	Set point: no PWM dimming, 4 x 15 LED's	0.45	0.5	0.55	A
$I_{AVG, LED Line Regulation}$	90 V_{RMS} to 264 V_{RMS}		0.0022	0.0044	
Shutdown Threshold ⁽¹⁾ ⁽²⁾	PFC: J2 Pin 1	0.72		1.1	V
	Buck: J4 Pin 1				
PWM Threshold ⁽²⁾		0.72		1.3	
PWM Frequency	Input signal, J4 Pin 3	200		1 k	Hz
Efficiency	Full load		89%		

⁽¹⁾ On initial startup the Buck stage shutdown signal (J4: pin1) should be set low before or simultaneous with the PFC shutdown signal. The two shutdown signals can be tied together.

⁽²⁾ The shutdown and PWM dimming pins are active high. A high signal on these pins disables the current to the LED's.

4 Schematic

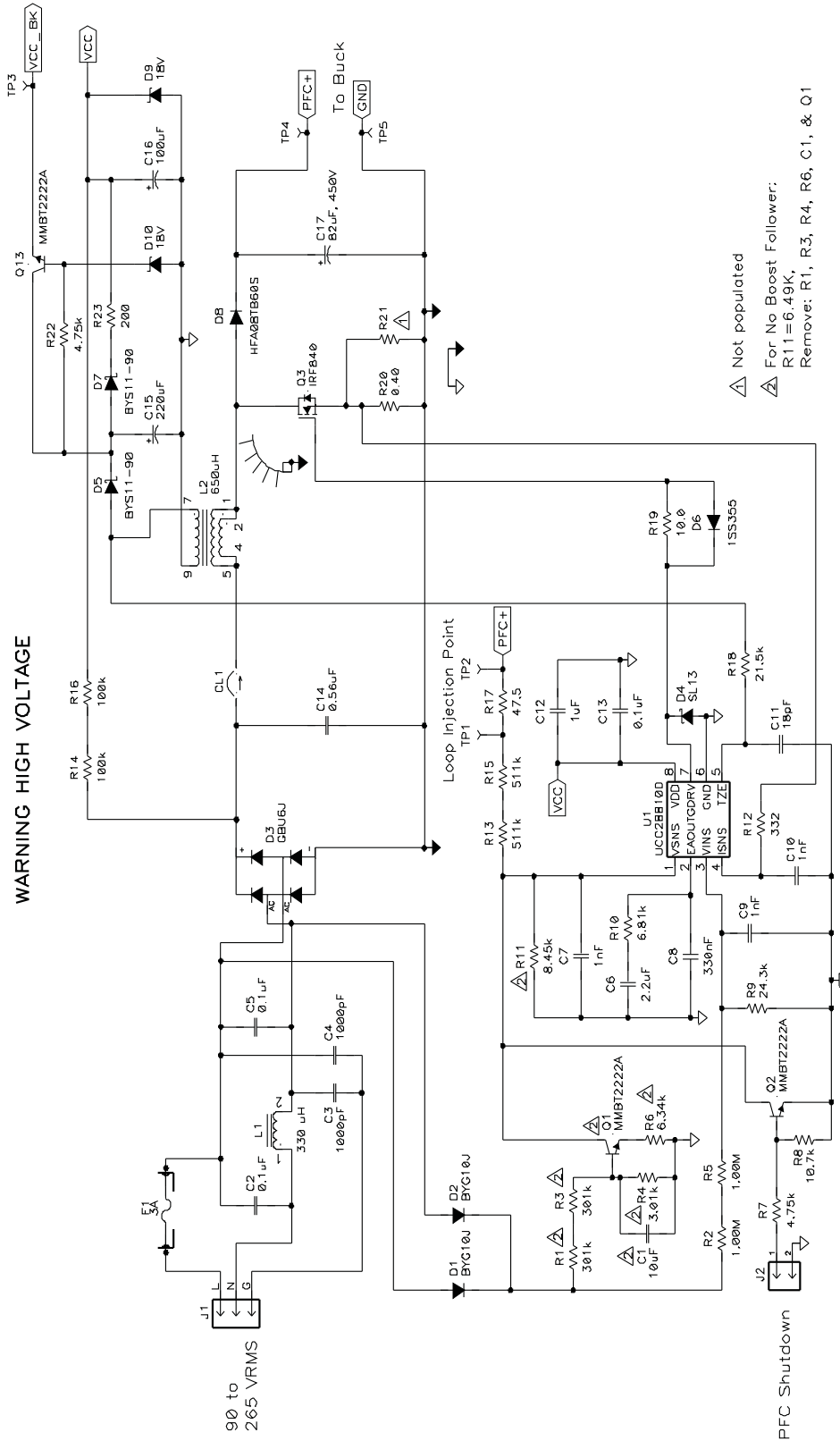

Figure 2. UCC28810EVM-003 PFC Stage Schematic

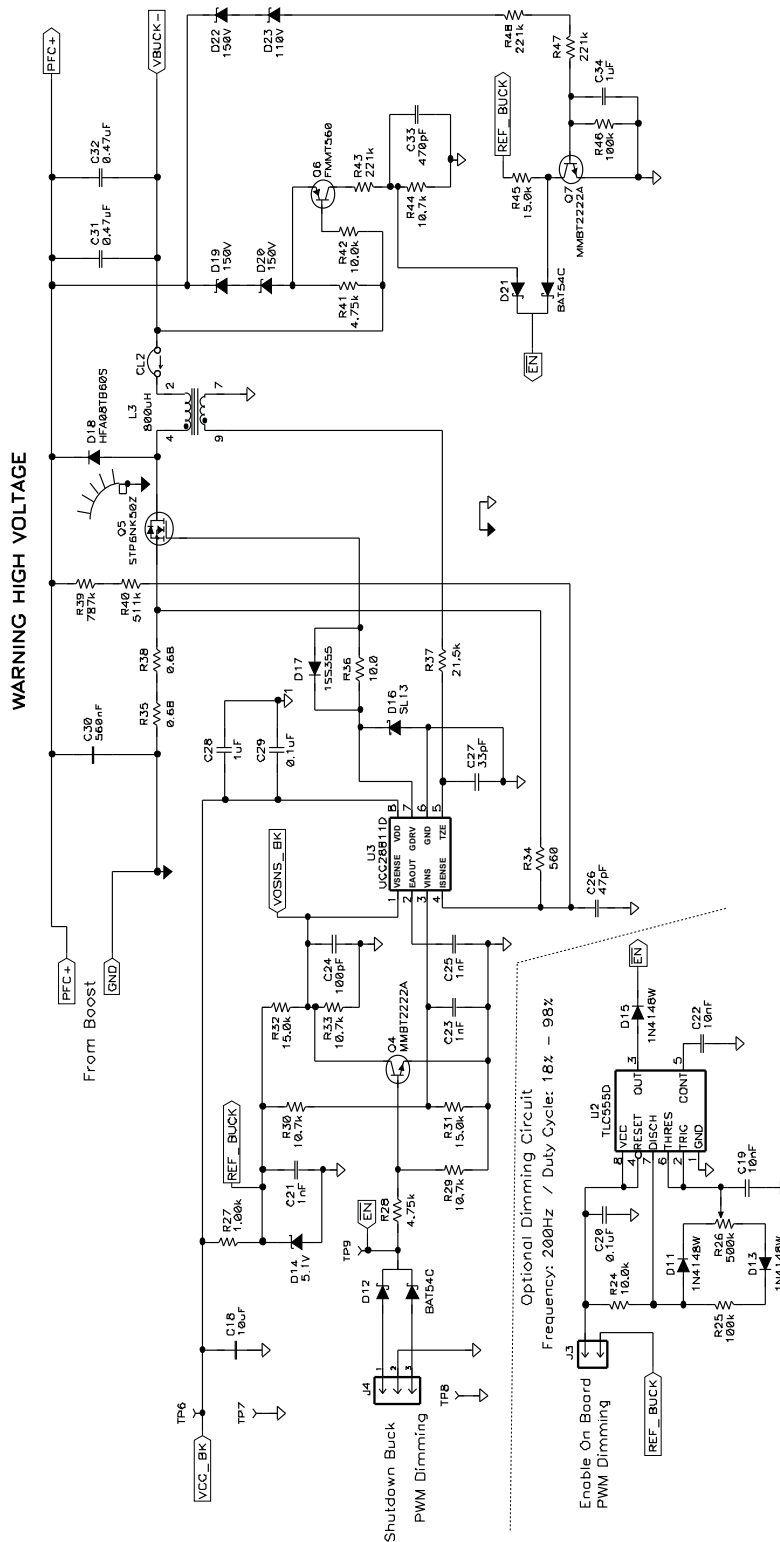
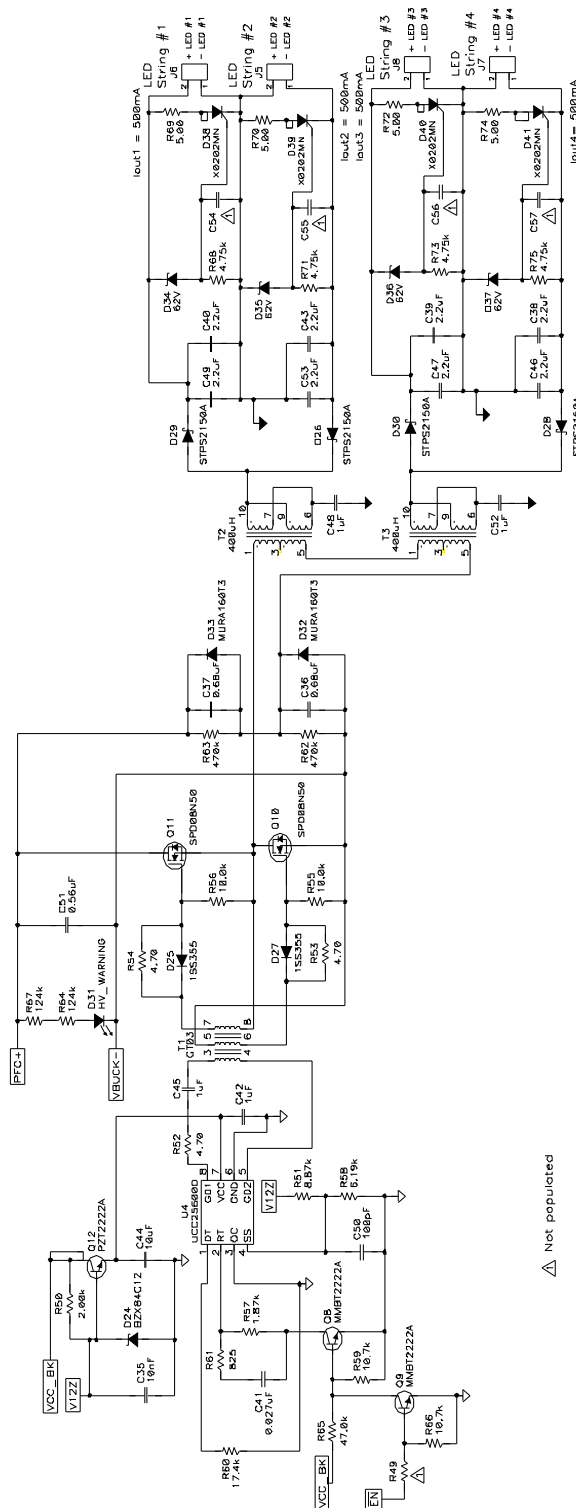

Figure 3. UCC28810EVM-003 Buck Stage Schematic

WARNING! HIGH VOLTAGE COMPONENTS MAY GET HOT



△ Not populated

Figure 4. UCC28810EVM-003 DC Transformer Schematic

5 Test Setup

WARNING

High voltages that may cause injury exist on this evaluation module (EVM). Please ensure all safety procedures are followed when working on this EVM. Never leave a powered EVM unattended. The use of isolated equipment is highly recommended.

5.1 Test Equipment

See [Figure 5](#) for recommended test set up.

- **Voltage Source:**
 - Source 1: Isolated AC voltage source or VARIAC, capable of 90 V_{RMS}/150 W.
 - Source 2: A 3.3-V DC source capable of 100 mA.
- **Multimeters:** Five digital multimeters are recommended, four for current measurement, A1-4 and one for voltage measurements, V1.
- **Output Load:** It is recommended that actual high brightness LED's are used for the load. They should be rated for at least 0.5 A. The HB-LEDs should be connected in 4 strings of 15 LEDs in series. Their voltage drop should be between 45 V and 58.5 V DC.
- **Oscilloscope:** A digital or analog oscilloscope with current probe is required to view the AC current in the PFC inductor or buck inductor.
- **Fan:** Forced air cooling is not required
- **Recommended Wire Gauge:** A minimum of AWG18 wire is recommended. Also the wire connections between the AC source and the EVM, and the EVM and load should be less than two feet long. The AC input connector accepts a standard IEC320-C13 connector with ground pin.

5.2 Recommended Test Setup

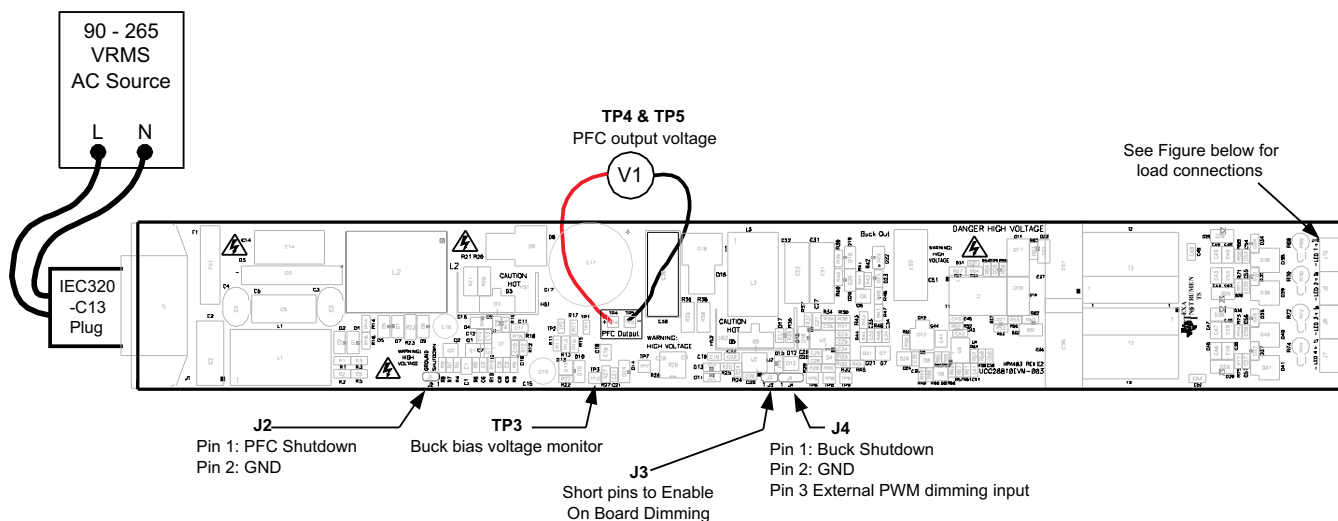

Figure 5. UCC28810EVM-003 Recommended Test Set Up

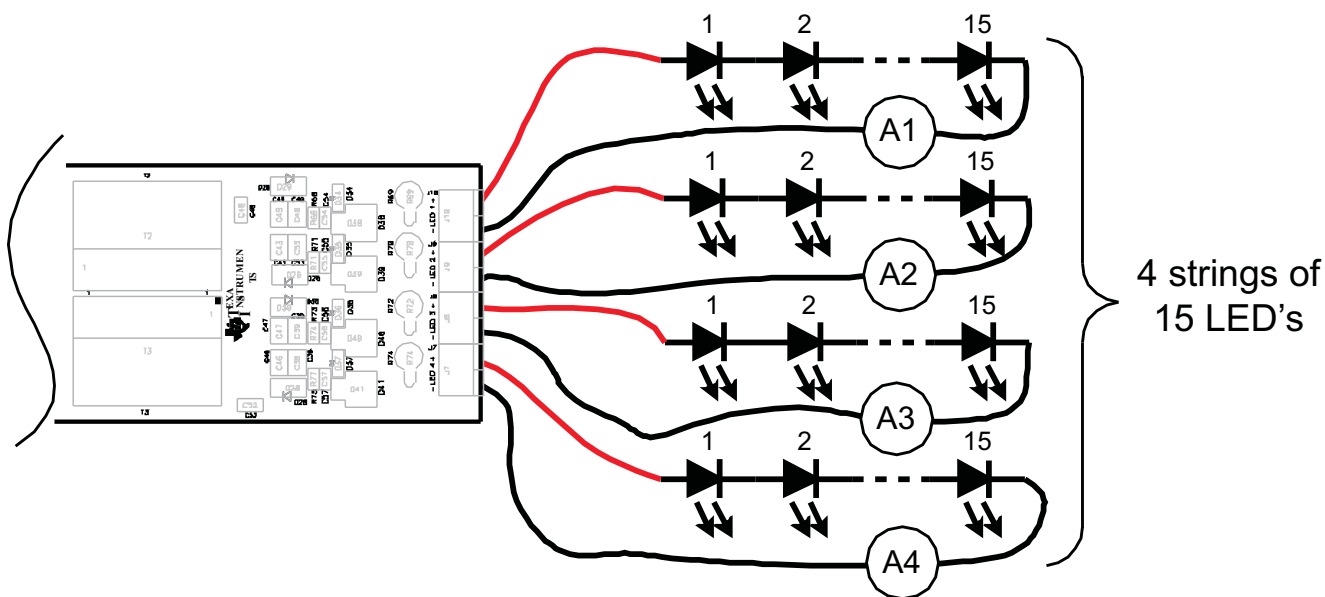

Figure 6. UCC28810EVM-003 Recommended Load Set Up

5.3 List of Test Points

Table 2. Test Point Functional Description

TEST POINTS	NAME	DESCRIPTION
TP1		Loop injection point.
TP2		Loop injection point, PFC output.
TP3	VCC_BK	Buck bias voltage output.
TP4	PFC Output+	PFC output voltage.
TP5	PFC Output-	PFC output voltage ground.
TP6	VCC_BK	Buck bias voltage input.
TP7	GND	Buck bias voltage ground.
TP8	GND	Ground connection.
TP9	$\overline{\text{EN}}$	Buck enable.
J2-1	PFC shutdown	Apply 3.3 V to this pin to shutdown PFC stage.
J2-2	GND	
J4-1	BK_Shutdown	Apply 3.3 V to this pin to shutdown buck stage.
J4-2	GND	
J4-3	PWM Dim	Input for external PWM dimming.
J3	On board dim	Short the two pins on J3 to enable on board PWM dimming. R26 varies dimming duty cycle.

6 Test Procedure

All tests should use the set up described in [Section 5](#) of this user guide. Ensure potentiometer R26 is rotated completely clockwise

WARNING

HIGH VOLTAGE levels are present on this evaluation module whenever it is energized. Proper precautions must be observed whenever working with this module. There is an energy storage capacitor (C17) on this module which must be discharged before the board can be handled. Serious injury can occur if proper safety procedures are not followed.

6.1 Applying Power to the EVM

1. Set up the EVM as described in [Section 5](#) of this user guide.
2. Ensure the AC source is off.
3. Ensure potentiometer R26 is rotated completely clockwise.
4. Ensure that each LED string voltage drop when operating is between 45 V to 58.5 V.
5. Set AC source to 90 V_{RMS} .
6. Turn on AC source.
7. Monitor PFC output voltage at TP4 and TP5, V1.
8. Monitor output current at A1-A4.
9. The EVM is now ready for testing.

6.2 Line Regulation and Efficiency Measurement Procedure

1. Apply power to the EVM per [Section 6.1](#).
2. Observe output currents on A1-A4 are equal.
3. Vary AC source from 90 V_{RMS} to 265 V_{RMS} .
4. Observe output current on A1-A4 stays constant.
5. PFC inductor ripple current can be measured at CL1 using an oscilloscope and current probe.
6. The buck output inductor current can be measured at CL2 using an oscilloscope and current probe.
7. See [Section 7](#) for some typical test results.

6.3 PFC Shut Down

1. Ensure the AC source is off.
2. Connect a DC source to J2.
3. Set DC source to 0 V.
4. Apply power to the EVM per [Section 6.1](#).
5. Increase DC source to 3.3 V. This input can accept up to 12 V.
6. Observe PFC output voltage reduces, V1.
7. PFC inductor ripple current loses high frequency component.

6.4 Buck Shut Down

1. Ensure the AC source is off.
2. Connect a DC source to J4, pins 1 and 2.
3. Set DC source to 0 V.
4. Apply power to the EVM per section 6.1
5. Increase DC source to 3.3 V. This input can accept up to 12 V.
6. Observe output current, A1, drops to zero.
7. PFC voltage, V1, does not change.

6.5 Internal Dimming Function

1. Ensure the AC source is off.
2. Ensure jumper is present on J3.
3. Apply power to the EVM per [Section 6.1](#).
4. Rotate R26 potentiometer slowly anti clockwise.
5. Observe output current on A1 reduce from nominal 0.5 A to 0.1 A. Observe LED's dim.

6.6 External Dimming Function

1. Ensure the AC source is off.
2. Ensure jumper is removed from J3.
3. Connect signal generator to J4, pins 3 and 2.
4. Set signal generator to generator a pulse from 0V to 3.3V at 200Hz with variable duty cycle.
5. Apply power to the EVM per [Section 6.1](#).
6. Vary the duty cycle of the signal generator output.
7. Observe output current, A1, changes. Observe LED's dim.

6.7 Equipment Shutdown

1. If DC sources are connected to shutdown pins, J2 and J4, ensure they are set to 0 V.
2. Ensure load is at maximum, this will help discharge C17.
3. Turn off AC source.
4. Monitor PFC output voltage V1. Do not handle EVM until V1 reads less than 50 V_{DC}.

7 Performance Data and Typical Characteristic Curves

Figure 7 through Figure 13 present some typical performance curves for the UCC28810EVM-003.

7.1 Efficiency

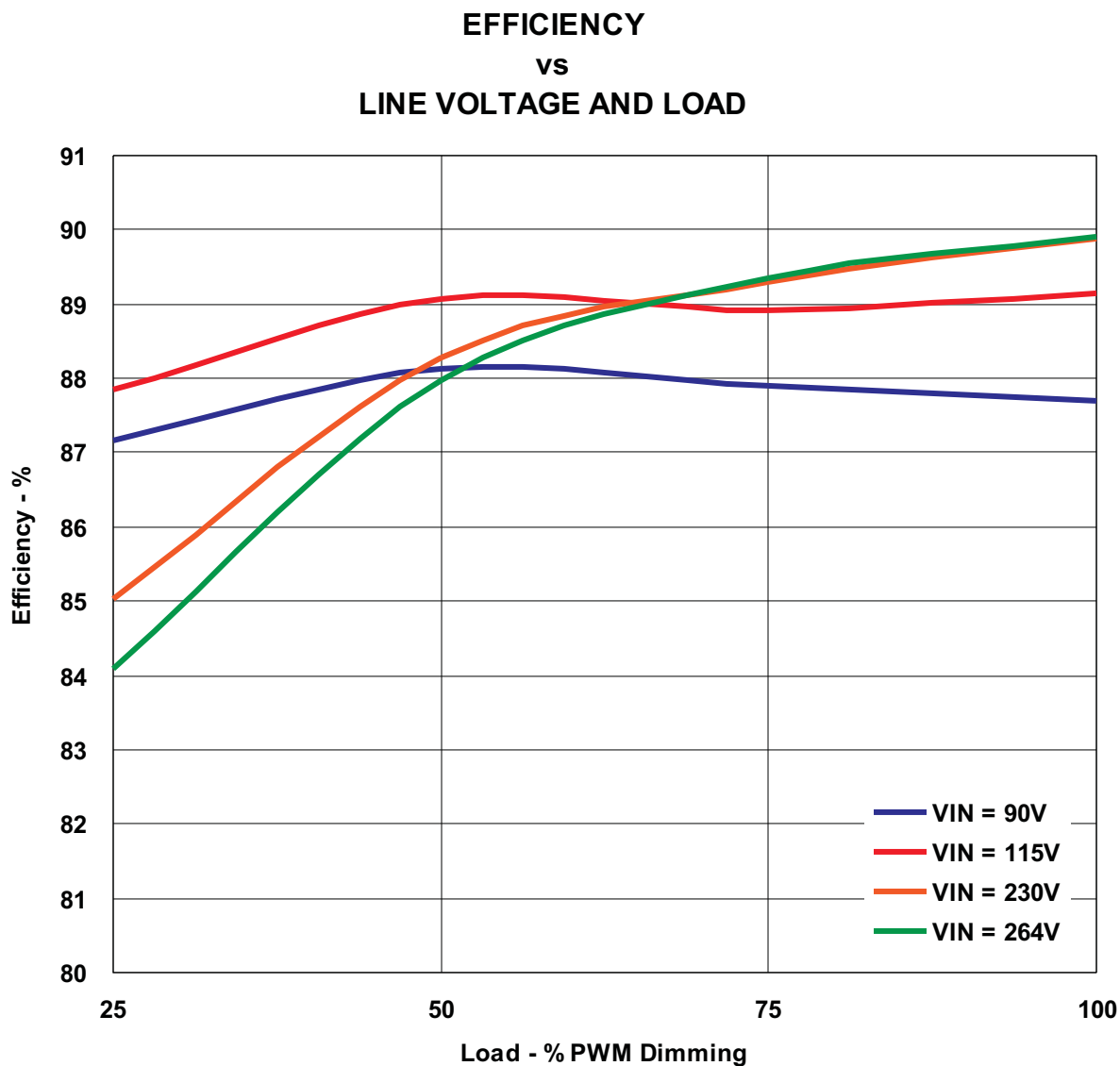

Figure 7. 4 x 15 Cree XRE LED's at 500 mA

7.2 Power Factor

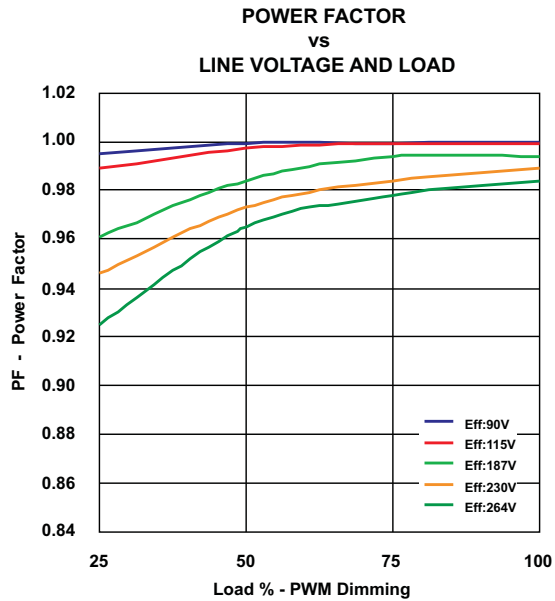

Figure 8. 4 x 15 Cree XRE LED's at 500 mA

7.3 I_{OUT} Matching vs. Line Voltage

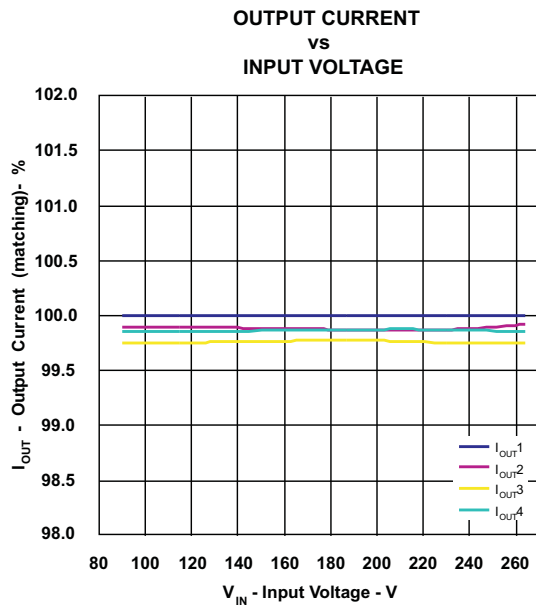

Figure 9. 4 x 15 Cree XRE LED's at 500 mA

7.4 Dimming Accuracy

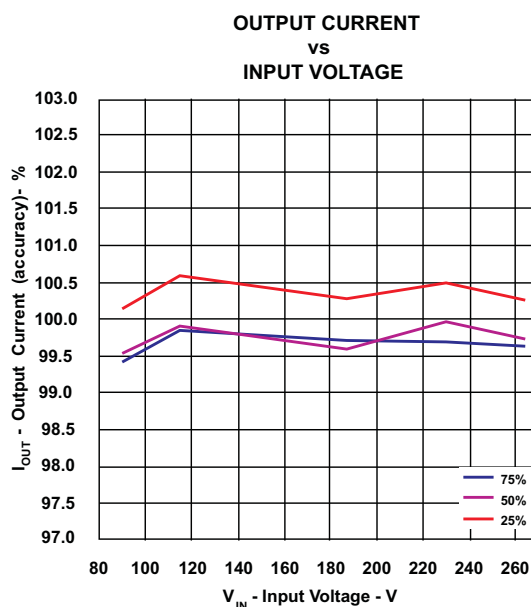

Figure 10. 4 x 15 Cree XRE LED's at 500 mA

7.5 Transient

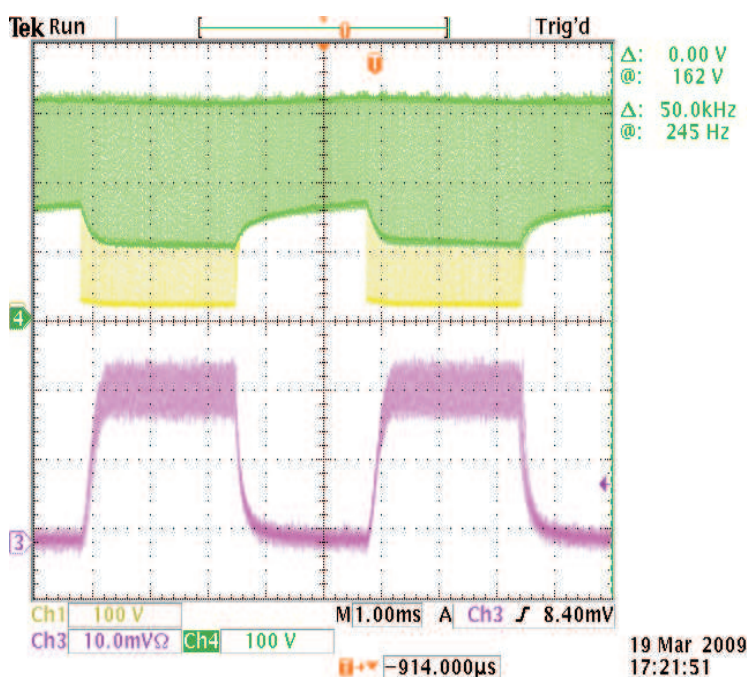

Figure 11. UCC28810EVM-003 Buck Only PWM Response (Ch1: Buck V_{DS} , Ch3 LED I_{out} 200 mA/Div, Ch4 DC Transformer Primary, Ch1 and Ch 4 Share GND reference)

8 EVM Assembly Drawing and PCB layout

The following figures (Figure 14 through Figure 16) show the design of the UCC28810EVM-003 printed circuit board.



Figure 14. Top Layer Assembly Drawing (top view)

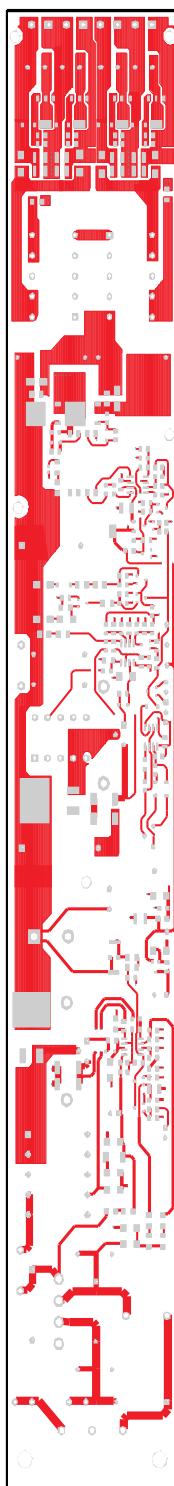

Figure 15. Top Copper (top view)

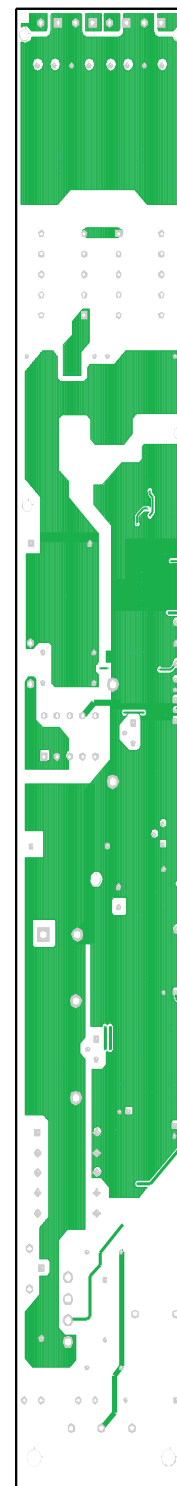

Figure 16. Bottom Layer (viewed through top layer)

9 List of Materials

Table 3. The UCC28810EVM-003 components list according to the schematic shown in Figure 2, Figure 3 and Figure 4

COUNT	REFDES	DESCRIPTION	PART NUMBER	MFR
3	C1,C18, C44	Capacitor, ceramic, 10 μ F, 25 V, X7R, \pm 10%, 1210	Std	Std
2	C2, C5	Capacitor, metallized polyester film, 0.1 μ F, 275 VAC, \pm 10%, X2	ECQ-U2A104ML	Panasonic
2	C3, C4	Capacitor, ceramic disc, 1 nF, 250 V, Y1/X1	ECK-ANA102MB	Panasonic
1	C6	Capacitor, ceramic, 2.2 μ F, 25 V, X7R, \pm 10%	ECJ-2FB1E225K	Panasonic
6	C7, C9, C10, C21, C23, C25	Capacitor, ceramic, 1 nF, 50 V, NPO, \pm 5%, 0805	Std	Std
1	C8	Capacitor, ceramic, 330 nF, 16 V, X7R, \pm 10%, 0805	Std	Std
1	C11	Capacitor, ceramic, 18 pF, 50 V, NPO, \pm 5%, 1206	Std	Std
5	C12, C28, C34, C42, C45	Capacitor, ceramic, 1 μ F, 25 V, X7R, \pm 10%, 0805	Std	Std
3	C13, C20, C29	Capacitor, ceramic, 0.1 μ F, 25 V, X7R, \pm 10%, 0805	Std	Std
2	C14, C51	Capacitor, polypropylene film, 0.56 μ F, 400 V, \pm 5%	ECW-F4564JL	Panasonic
1	C15	Capacitor, aluminum electrolytic, 220 μ F, 35 V, \pm 20%, 8x11.5 mm	Std	Std
1	C16	Capacitor, aluminum electrolytic, 100 μ F, 35 V, \pm 20%, 6.3x11.5 mm	Std	Std
1	C17	Capacitor, aluminum electrolytic, 82 μ F, 450 V, TS-HB	ECO-S2WB820BA	Panasonic
3	C19, C22, C35	Capacitor, ceramic, 10 nF, 50 V, X7R, \pm 10%, 0805	Std	Std
2	C24, C50	Capacitor, ceramic, 100 pF, 50 V, NPO, \pm 5%, 0805	Std	Std
1	C26	Capacitor, ceramic, 47 pF, 50 V, NPO, \pm 5%, 0805	Std	Std
1	C27	Capacitor, ceramic, 33 pF, 50 V, NPO, \pm 5%, 1206	Std	Std
1	C30	Capacitor, polypropylene film, 0.56 μ F, 630 V, \pm 5%	ECW-F6564JL	Panasonic
2	C31, C32	Capacitor, metallized polyester film, 0.47 μ F, 400 V, \pm 10%	ECQ-E4474KF	Panasonic
1	C33	Capacitor, ceramic, 470 pF, 50 V, NPO, \pm 5%, 0805	Std	Std
2	C36, C37	Capacitor, polypropylene film, 0.68 μ F, 250 V, \pm 5%	ECWF2684JB	Panasonic
8	C38, C39, C40, C43, C46, C47, C49, C53	Capacitor, ceramic, 2.2 μ F, 100 V, X7R, \pm 10% 1210	Std	Std
1	C41	Capacitor, ceramic, 0.027 μ F, 50 V, X7R, \pm 10%, 0805	Std	Std
2	C48, C52	Capacitor, ceramic, 1 μ F, 100 V, X7R, \pm 10%, 1206	Std	Std
2	D1, D2	Diode, 1.5 A, 600 V	BYG10J-E3/TR	Vishay
1	D3	Diode, bridge rectifier, 6 A, 600 V	GBU6J	Diodes Inc
2	D4, D16	Diode, schottky, 1.5 A, 30 V	SL13-E3/61T	Vishay
2	D5, D7	Diode, schottky, 1 A, 90 V	BYS11-90-E3/TR	Vishay
4	D6, D17, D25, D27	Diode, switching, 90 V, 225 mA, high speed, SOD-323	1SS355	Rohm
2	D8, D18	Diode, ultra fast, 8 A, 600 V	HFA08TB60SPbF	IR
2	D9, D10	Diode, Zener, 18 V, 1 W, SMA	SMAZ18-13-F	Diodes Inc
3	D11, D13, D15	Diode, signal, 150 mA, 75 V, 350 mW, SOD-123	1N4148W-V	Vishay
2	D12, D21	Diode, dual Schottky, 200 mA, 30 V, SOT-23	BAT54C	Vishay
1	D14	Diode, Zener, 5.1 V, 1 W, SMA	SMAZ5V1-13-F	Diodes Inc
3	D19, D20, D22	Diode, Zener, 150 V, 1.5 W	BZG03C150	Vishay
1	D23	Diode, Zener, 500 mW, 110 V, SOD-123	MMSZ5272BT3G	ONsemi
1	D24	Diode, Zener, 12 V, 20 mA, 225 mW, 5%	BZX84C12-V	Vishay

Table 3. The UCC28810EVM-003 components list according to the schematic shown in Figure 2, Figure 3 and Figure 4 (continued)

COUNT	REFDES	DESCRIPTION	PART NUMBER	MFR
4	D26, D28, D29, D30	Diode, Schottky, 2 A, 150 V, SMA	STPS2150A	ST
1	D31	Diode, LED, red, 2.1 V, 20 mA, 6 mcd	LTST-C190CKT	Lite On
2	D32, D33	Rectifier, SMD ultrafast power, 600 V, 1 A, SMA	MURA160T3	Onsemi
4	D34, D35, D36, D37	Diode, Zener, 500 mW, 62 V	MMSZ5265BT1G	Onsemi
4	D38, D39, D40, D41	SCR, 600 V, 1.25 A	X0202MN 5BA4	ST
1	F1	Fuse, slow, 5 x 20 mm, 3 A, 250 V	BK/GMD-3A	Cooper/Bussmann
2	FH1	Fuse clip, 5x20 mm, PC mount	01000056H	Wickmann
2	HS1, HS2	Heatsink, TO-220, vertical mount, 15°C/W	593002B03400G	Aavid
1	J1	Connector, AC receptacle, board mount, R/A, 9 mm	703W-00/54	Qualtek
2	J2, J3	Header, male 2 pin, 100-mil spacing, (36-pin strip)	PTC02SAAN	Sullins
1	J4	Header, male 3 pin, 100-mil spacing, (36-pin strip)	PTC03SAAN	Sullins
4	J7, J8, J9, J10	Terminal block, 2 pin, 15 A, 5.1 mm	D120/2DS	OST
1	L1	Inductor, thru hole, 3 A, 150 mΩ	2218-V-RC	Bourns
1	L2	Inductor, 1 primary, 1 secondary, 650 μH, 3.25A	CTX33-18441	Cooper/Bussmann
1	L3	Inductor, 1 primary, 1 secondary, 800 μH, 1A	CTX16-18625	Cooper/Bussmann
7	Q1, Q2, Q4, Q7, Q8, Q9, Q13	Transistor, NPN, 75 V _{CE0} , 600 mA	MMBT2222A	FAIRCHILD
1	Q3	MOSFET, N-channel, 400 V, 10 A, 0.85 Ω	IRF840PBF	IR
1	Q5	MOSFET, N-channel, 500 V, 6 A	STP6NK50Z	ST
1	Q6	Bipolar, PNP, -500 V, -500 mA	FMMT560	Zetex
2	Q10, Q11	MOSFET, N-channel, 560 V, 7.6 A, 600 mΩ	SPD08N50	INFINEON
1	Q12	Trans, GP NPN amplifier, 40 V _{CE0} , 1 A	PZT2222A	Fairchild
2	R1, R3	Resistor, chip, 301 kΩ, 1/4 W, 1%, 1206	Std	Std
2	R2, R5	Resistor, chip, 1.00 MΩ, 1/4 W, 1%, 1206	Std	Std
1	R4	Resistor, chip, 3.01 kΩ, 1/8 W, 1%, 0805	Std	Std
1	R6	Resistor, chip, 6.34 kΩ, 1/8 W, 1%, 0805	Std	Std
7	R7, R22, R28, R68, R71, R73, R75	Resistor, chip, 4.75 kΩ, 1/8 W, 1%, 0805	Std	Std
7	R8, R29, R30, R33, R44, R59, R66	Resistor, chip, 10.7 kΩ, 1/8 W, 1%, 0805	Std	Std
1	R9	Resistor, chip, 24.3 kΩ, 1/8 W, 1%, 0805	Std	Std
1	R10	Resistor, chip, 6.81 kΩ, 1/8 W, 1%, 0805	Std	Std
1	R11	Resistor, chip, 8.45 kΩ, 1/8 W, 1%, 0805	Std	Std
1	R12	Resistor, chip, 332 Ω, 1/8 W, 1%, 0805	Std	Std
3	R13, R15, R40	Resistor, chip, 511 kΩ, 1/4 W, 1%, 1206	Std	Std
2	R14, R16	Resistor, chip, 100 kΩ, 1/4 W, 1%, 1206	Std	Std
1	R17	Resistor, chip, 47.5 Ω, 1/8 W, 1%, 0805	Std	Std
2	R18, R37	Resistor, chip, 21.5 kΩ, 1/8 W, 1%, 0805	Std	Std
1	R19, R36	Resistor, chip, 10.0 Ω, 1/8 W, 1%, 0805	Std	Std
1	R20	Resistor, chip, 0.40 Ω, 1 W, 1%, 2512	Std	Std
1	R23	Resistor, chip, 200 Ω, 1/2 W, 5%, 2010	Std	Std
4	R24, R42, R55, R56	Resistor, chip, 10.0 kΩ, 1/8 W, 1%, 0805	Std	Std
2	R25, R46	Resistor, chip, 100 kΩ, 1/8 W, 1%, 0805	Std	Std
1	R26	Potentiometer, 3/8 cermet, single turn, Flat, 500 kΩ	3362P-504	Bourns
1	R27	Resistor, chip, 1.00 kΩ, 1/4 W, 1%, 1206	Std	Std
3	R31, R32, R45	Resistor, chip, 15.0 kΩ, 1/8 W, 1%, 0805	Std	Std
1	R34	Resistor, chip, 560 Ω, 1/8 W, 1%, 0805	Std	Std

Table 3. The UCC28810EVM-003 components list according to the schematic shown in [Figure 2](#), [Figure 3](#) and [Figure 4](#) (continued)

COUNT	REFDES	DESCRIPTION	PART NUMBER	MFR
2	R35, R38	Resistor, chip, 0.68 Ω , 1 W, 1%, 2512	Std	Std
1	R39	Resistor, chip, 787 k Ω , 1/4 W, 1%, 1206	Std	Std
1	R41	Resistor, chip, 4.75 k Ω , 1/4 W, 1%, 1206	Std	Std
3	R43, R47, R48	Resistor, chip, 221 k Ω , 1/4 W, 1%, 1206	Std	Std
1	R50	Resistor, chip, 2.00 k Ω , 1/8 W, 1%, 0805	Std	Std
1	R51	Resistor, chip, 8.87 k Ω , 1/8 W, 1%, 0805	Std	Std
1	R52, R53, R54	Resistor, chip, 4.70 Ω , 1/8 W, 1%, 0805	Std	Std
1	R57	Resistor, chip, 1.87 k Ω , 1/8 W, 1%, 0805	Std	Std
1	R58	Resistor, chip, 6.19 k Ω , 1/8 W, 1%, 0805	Std	Std
1	R60	Resistor, chip, 17.4 k Ω , 1/8 W, 1%, 0805	Std	Std
1	R61	Resistor, chip, 825 Ω , 1/8 W, 1%, 0805	Std	Std
2	R62, R63	Resistor, chip, 470 k Ω , 1/4 W, 1%, 1206	Std	Std
2	R64, R67	Resistor, chip, 124 k Ω , 1/4 W, 1%, 1206	Std	Std
1	R65	Resistor, chip, 47.0 k Ω , 1/8 W, 1%, 0805	Std	Std
4	R69, R70, R72, R74	Resistor, wire wound, 5.00 Ω , 3 W, 5%,	AC03000005008JAC00	Vishay
1	T1	Xfmr, center tapped, voice over IP	GT03-111-110-A	ICE
2	T2, T3	Transformer, half bridge	CTX16-18610	Cooper/Bussmann
1	U1	LED Lighting Power Controller	UCC28810D	TI
1	U2	Timer, Low-Power CMOS	TLC555CDR	TI
1	U3	LED Lighting Power Controller	UCC28811DR	TI
1	U4	Resonant Mode Controller	UCC25600D	TI

EVALUATION BOARD/KIT IMPORTANT NOTICE

Texas Instruments (TI) provides the enclosed product(s) under the following conditions:

This evaluation board/kit is intended for use for **ENGINEERING DEVELOPMENT, DEMONSTRATION, OR EVALUATION PURPOSES ONLY** and is not considered by TI to be a finished end-product fit for general consumer use. Persons handling the product(s) must have electronics training and observe good engineering practice standards. As such, the goods being provided are not intended to be complete in terms of required design-, marketing-, and/or manufacturing-related protective considerations, including product safety and environmental measures typically found in end products that incorporate such semiconductor components or circuit boards. This evaluation board/kit does not fall within the scope of the European Union directives regarding electromagnetic compatibility, restricted substances (RoHS), recycling (WEEE), FCC, CE or UL, and therefore may not meet the technical requirements of these directives or other related directives.

Should this evaluation board/kit not meet the specifications indicated in the User's Guide, the board/kit may be returned within 30 days from the date of delivery for a full refund. **THE FOREGOING WARRANTY IS THE EXCLUSIVE WARRANTY MADE BY SELLER TO BUYER AND IS IN LIEU OF ALL OTHER WARRANTIES, EXPRESSED, IMPLIED, OR STATUTORY, INCLUDING ANY WARRANTY OF MERCHANTABILITY OR FITNESS FOR ANY PARTICULAR PURPOSE.**

The user assumes all responsibility and liability for proper and safe handling of the goods. Further, the user indemnifies TI from all claims arising from the handling or use of the goods. Due to the open construction of the product, it is the user's responsibility to take any and all appropriate precautions with regard to electrostatic discharge.

EXCEPT TO THE EXTENT OF THE INDEMNITY SET FORTH ABOVE, NEITHER PARTY SHALL BE LIABLE TO THE OTHER FOR ANY INDIRECT, SPECIAL, INCIDENTAL, OR CONSEQUENTIAL DAMAGES.

TI currently deals with a variety of customers for products, and therefore our arrangement with the user **is not exclusive.**

TI assumes **no liability for applications assistance, customer product design, software performance, or infringement of patents or services described herein.**

Please read the User's Guide and, specifically, the Warnings and Restrictions notice in the User's Guide prior to handling the product. This notice contains important safety information about temperatures and voltages. For additional information on TI's environmental and/or safety programs, please contact the TI application engineer or visit www.ti.com/esh.

No license is granted under any patent right or other intellectual property right of TI covering or relating to any machine, process, or combination in which such TI products or services might be or are used.

FCC Warning

This evaluation board/kit is intended for use for **ENGINEERING DEVELOPMENT, DEMONSTRATION, OR EVALUATION PURPOSES ONLY** and is not considered by TI to be a finished end-product fit for general consumer use. It generates, uses, and can radiate radio frequency energy and has not been tested for compliance with the limits of computing devices pursuant to part 15 of FCC rules, which are designed to provide reasonable protection against radio frequency interference. Operation of this equipment in other environments may cause interference with radio communications, in which case the user at his own expense will be required to take whatever measures may be required to correct this interference.

EVM WARNINGS AND RESTRICTIONS

It is important to operate this EVM within the input voltage range of 90 V_{AC} to 265 V_{AC} and the output current of 0.5 A .

Exceeding the specified input range may cause unexpected operation and/or irreversible damage to the EVM. If there are questions concerning the input range, please contact a TI field representative prior to connecting the input power.

Applying loads outside of the specified output range may result in unintended operation and/or possible permanent damage to the EVM. Please consult the EVM User's Guide prior to connecting any load to the EVM output. If there is uncertainty as to the load specification, please contact a TI field representative.

During normal operation, some circuit components may have case temperatures greater than 100 °C. The EVM is designed to operate properly with certain components above as long as the input and output ranges are maintained. These components include but are not limited to linear regulators, switching transistors, pass transistors, and current sense resistors. These types of devices can be identified using the EVM schematic located in the EVM User's Guide. When placing measurement probes near these devices during operation, please be aware that these devices may be very warm to the touch.

Mailing Address: Texas Instruments, Post Office Box 655303, Dallas, Texas 75265
Copyright © 2009, Texas Instruments Incorporated

IMPORTANT NOTICE

Texas Instruments Incorporated and its subsidiaries (TI) reserve the right to make corrections, modifications, enhancements, improvements, and other changes to its products and services at any time and to discontinue any product or service without notice. Customers should obtain the latest relevant information before placing orders and should verify that such information is current and complete. All products are sold subject to TI's terms and conditions of sale supplied at the time of order acknowledgment.

TI warrants performance of its hardware products to the specifications applicable at the time of sale in accordance with TI's standard warranty. Testing and other quality control techniques are used to the extent TI deems necessary to support this warranty. Except where mandated by government requirements, testing of all parameters of each product is not necessarily performed.

TI assumes no liability for applications assistance or customer product design. Customers are responsible for their products and applications using TI components. To minimize the risks associated with customer products and applications, customers should provide adequate design and operating safeguards.

TI does not warrant or represent that any license, either express or implied, is granted under any TI patent right, copyright, mask work right, or other TI intellectual property right relating to any combination, machine, or process in which TI products or services are used. Information published by TI regarding third-party products or services does not constitute a license from TI to use such products or services or a warranty or endorsement thereof. Use of such information may require a license from a third party under the patents or other intellectual property of the third party, or a license from TI under the patents or other intellectual property of TI.

Reproduction of TI information in TI data books or data sheets is permissible only if reproduction is without alteration and is accompanied by all associated warranties, conditions, limitations, and notices. Reproduction of this information with alteration is an unfair and deceptive business practice. TI is not responsible or liable for such altered documentation. Information of third parties may be subject to additional restrictions.

Resale of TI products or services with statements different from or beyond the parameters stated by TI for that product or service voids all express and any implied warranties for the associated TI product or service and is an unfair and deceptive business practice. TI is not responsible or liable for any such statements.

TI products are not authorized for use in safety-critical applications (such as life support) where a failure of the TI product would reasonably be expected to cause severe personal injury or death, unless officers of the parties have executed an agreement specifically governing such use. Buyers represent that they have all necessary expertise in the safety and regulatory ramifications of their applications, and acknowledge and agree that they are solely responsible for all legal, regulatory and safety-related requirements concerning their products and any use of TI products in such safety-critical applications, notwithstanding any applications-related information or support that may be provided by TI. Further, Buyers must fully indemnify TI and its representatives against any damages arising out of the use of TI products in such safety-critical applications.

TI products are neither designed nor intended for use in military/aerospace applications or environments unless the TI products are specifically designated by TI as military-grade or "enhanced plastic." Only products designated by TI as military-grade meet military specifications. Buyers acknowledge and agree that any such use of TI products which TI has not designated as military-grade is solely at the Buyer's risk, and that they are solely responsible for compliance with all legal and regulatory requirements in connection with such use.

TI products are neither designed nor intended for use in automotive applications or environments unless the specific TI products are designated by TI as compliant with ISO/TS 16949 requirements. Buyers acknowledge and agree that, if they use any non-designated products in automotive applications, TI will not be responsible for any failure to meet such requirements.

Following are URLs where you can obtain information on other Texas Instruments products and application solutions:

Products

Amplifiers	amplifier.ti.com
Data Converters	dataconverter.ti.com
DLP® Products	www.dlp.com
DSP	dsp.ti.com
Clocks and Timers	www.ti.com/clocks
Interface	interface.ti.com
Logic	logic.ti.com
Power Mgmt	power.ti.com
Microcontrollers	microcontroller.ti.com
RFID	www.ti-rfid.com
RF/IF and ZigBee® Solutions	www.ti.com/lprf

Applications

Audio	www.ti.com/audio
Automotive	www.ti.com/automotive
Broadband	www.ti.com/broadband
Digital Control	www.ti.com/digitalcontrol
Medical	www.ti.com/medical
Military	www.ti.com/military
Optical Networking	www.ti.com/opticalnetwork
Security	www.ti.com/security
Telephony	www.ti.com/telephony
Video & Imaging	www.ti.com/video
Wireless	www.ti.com/wireless

Mailing Address: Texas Instruments, Post Office Box 655303, Dallas, Texas 75265
Copyright © 2009, Texas Instruments Incorporated