

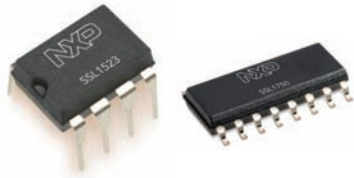

High-Efficiency AC/DC LED Driver Solutions

The SSL152x, SSL16xx, and SSL1750 families of offline switched-mode power supply (SMPS) controllers are ideal for driving the latest high-brightness LEDs with high efficiency and a full suite of built-in protection features. For SSL indoor lighting solutions below 15W, the SSL152x family is the right choice. The ICs operate directly from the rectified universal mains. They are ideal for retrofitting LED lamps and for LED driver solutions used in cabinet, kitchen, and many other lighting applications in the home. With just a minimum of additional components it offers a driver solution that is fully compatible with transistor- and thyristor- (TRIAC-) based wall-mounted dimmers. Between 15W and 24W, the SSL1623PH is very suitable for SSL applications due to the special heat spreader underneath the IC package. For SSL applications higher than 25W, NXP offers the SSL1750, flyback control, and power-factor correction (PFC) integrated into one IC.



SSL1523 and SSL1750

Features ▶

- Universal mains 80 VAC to 270 VAC
- Support of power-factor correction when required
- Wide range of built-in protection circuits
- Meets safety/isolation regulations (UL 1598 Class 2 and IEC60950)

Benefits ▶

- High-energy efficiency—valley switching for minimum switch-on loss
- Wide input voltage range
- Wide current drive capability
- Supports next generation of HB-LEDs

Applications ▶

- General LED lighting indoor (residential, office, and building)
- General LED lighting outdoor (street lighting, parking lots, tunnel lighting)
- Industrial lighting
- Signage

Product Specifications ▶												
Part Number	Type	Dimming Type	Number of LEDs/ String	Number of Strings	Configuration	Input Voltage (VDC)	Output Voltage (VDC)	Output Current (mA)	Peak Efficiency (%)	Diagnostic Capabilities*	Interface	Markets
SSL152x	Flyback SMPS	PWM and TRIAC-transistor	Pending on output wattage selected	–	String/series	80-276	User defined	User defined	Application defined	TSD/OVM	AC/DC	CL SI
SSL153x		PWM	Pending on output wattage selected	–	String/series	80-276	User defined	User defined	Application defined	TSD/OVM	AC/DC	CL SI
SSL1623PH		PWM and TRIAC-transistor	Pending on output wattage selected	–	String/series	80-276	User defined	User defined	Application defined	TSD/OVM	AC/DC	CL SI
SSL1750		PWM	Pending on output wattage selected	–	String/series	80-276	User defined	User defined	Application defined	TSD/OVM	AC/DC	CL SI
SSL1610	Resonant power supply	–	Pending on output wattage selected	–	String/series	80-276	User defined	User defined	Application defined	TSD/OVM	AC/DC	CL SI

MARKETS LEGEND

CL COMMERCIAL LIGHTING FL FLASHLIGHTS TR TRANSPORTATION BL BACKLIGHTING SI SIGNAGE

*Diagnostic capabilities: TSD: Thermal shutdown, OVM: Output voltage monitoring

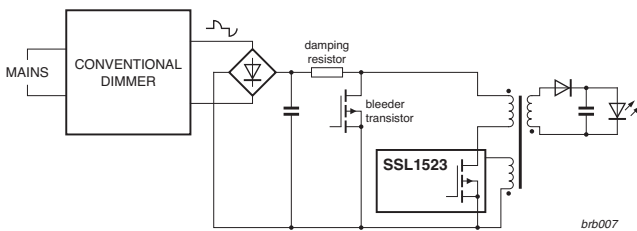

Basic application diagram—SSL152x

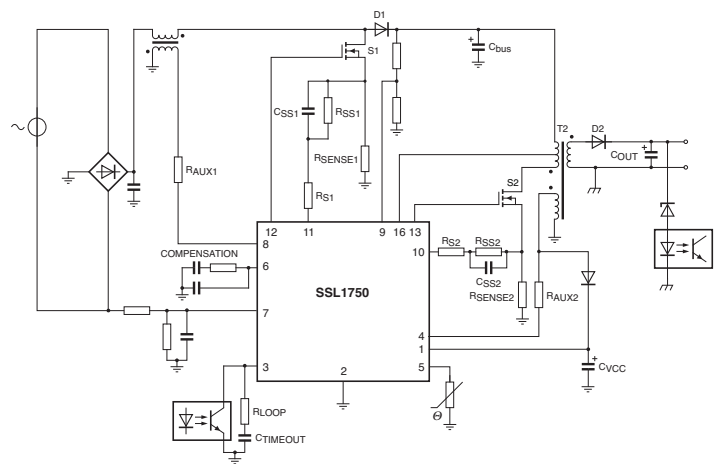

Basic application diagram—SSL1750

DC/DC LED Driver Solutions

The UBA3070 is a versatile high-voltage LED controller IC designed for applications where a high number of LEDs need to be driven in an accurate and highly energy efficient way. The flexible design allows the use of both low-power or high-power LEDs and can be used in combination with LED-strings containing hundreds of LEDs.



Features ▶

- Direct PWM dimming
- LED thermal and IC overheating protection
- Accurate DC/DC conversion with switch-mode buck converter

Benefits ▶

- Lower system costs
- Higher reliability and extended IC lifetime
- Supports next generation of HB-LEDs

Applications ▶

- General LED lighting (spotlights and downlights)
- General LED lighting (retail display)
- Channel letter and contour lighting
- Signage
- LCD backlighting



UBA3070

Product Specifications ▶

Part Number	Type	Dimming Type	Number of LEDs/String	Number of Strings	Configuration	Input Voltage (VDC)	Output Voltage (VDC)	Output Current (mA)	Peak Efficiency (%)	Diagnostic Capabilities*	Interface	Markets
UBA3070	LED driver	PWM	Up to 200	-	String/series	600	-	User defined	Application defined	TSD/OVM	DC/DC	CL BL SI

MARKETS LEGEND

CL COMMERCIAL LIGHTING FL FLASHLIGHTS TR TRANSPORTATION BL BACKLIGHTING SI SIGNAGE

*Diagnostic capabilities: TSD: Thermal shutdown, OVM: Output voltage monitoring

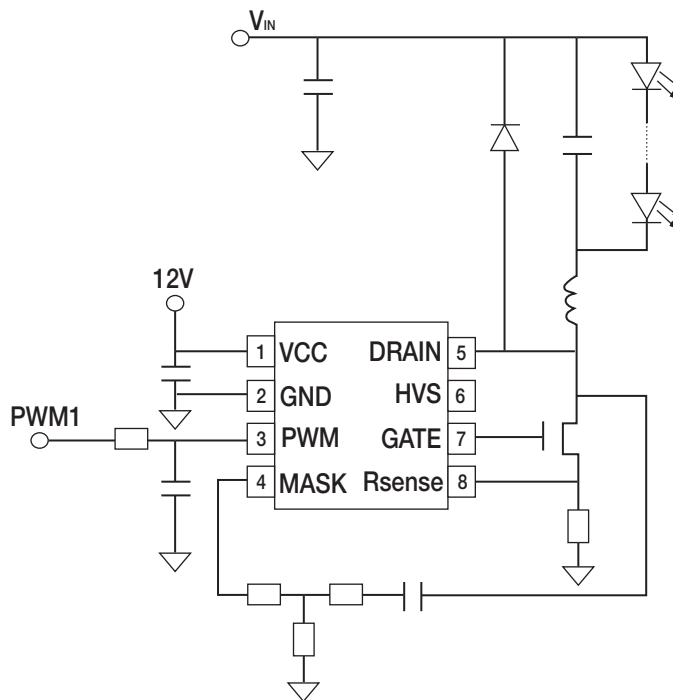

Basic application diagram—UBA3070

Fast and Connected ARM7® for Lighting Control Systems



NXP Semiconductors' newest entry in a growing line of ARM7® microcontrollers is a perfect fit for "Connected Lighting Controller" applications. NXP combines the high-performance connectivity of a dual-AHB architecture, enlightened combinations of peripherals (Ethernet, USB OTG, and CAN) with unique, fast, and deterministic I/O ports. With the embedded Ethernet MAC and the feature-rich serial ports, designers can use the LPC24xx as a bridge from IP to DMX512. The fast I/O ports are perfect for software-based PWM intensity control of light sources. Add an external LCD controller and gain the potential for a cost-effective touchscreen lighting scene controller.

Features ▶

- 72 MHz, 32-bit ARM7TDMI-S with dual-AHB buses and DMA
- Fast I/O suitable for bit-banging PWM outputs at up to 17.5 MHz
- 10/100 Ethernet MAC interface with DMA and MII/RMII interface
- Wide range of peripherals, including CAN, I²S, ADC, and PWM

Benefits ▶

- Dual buses with DMA allow concurrent transactions to get the most performance possible
- External interfaces provide flexibility regarding peripherals and memory
- Give customers the flexibility of lighting control with Ethernet

Applications ▶

- Architectural or landscape lighting
- Signage and gaming
- DMX512-to-Ethernet bridges

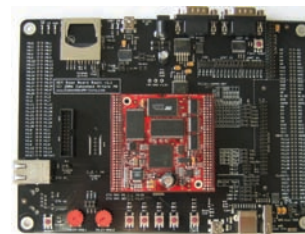

LPC2468 demo board (OM10010)

Product Specifications ▶

Part Number	Type	PWM Ch. (#)/ Res. (bits)	Flash (KB)	RAM (KB)	ZigBee® Enabled (Y/N)	Core Supply (V)	IO Supply (V)	I ² C/Ch. (#)	UART/Ch. (#)	SPI/Ch. (#)	Operating Temperature (°C)	Markets
LPC2460	General purpose ARM7® microcontroller with Ethernet, USB, and CAN	HW: 2 PWM/4 timers SW: Scalable	-	98	N	3.0-3.6	3.0-3.6	3	4	3	-40 to +85	CL TR BL SI
LPC2468		HW: 2 PWM/4 timers SW: Scalable	512	98	N	3.0-3.6	3.0-3.6	3	4	3	-40 to +85	CL TR BL SI

MARKETS LEGEND CL COMMERCIAL LIGHTING FL FLASHLIGHTS TR TRANSPORTATION BL BACKLIGHTING SI SIGNAGE

Development software required

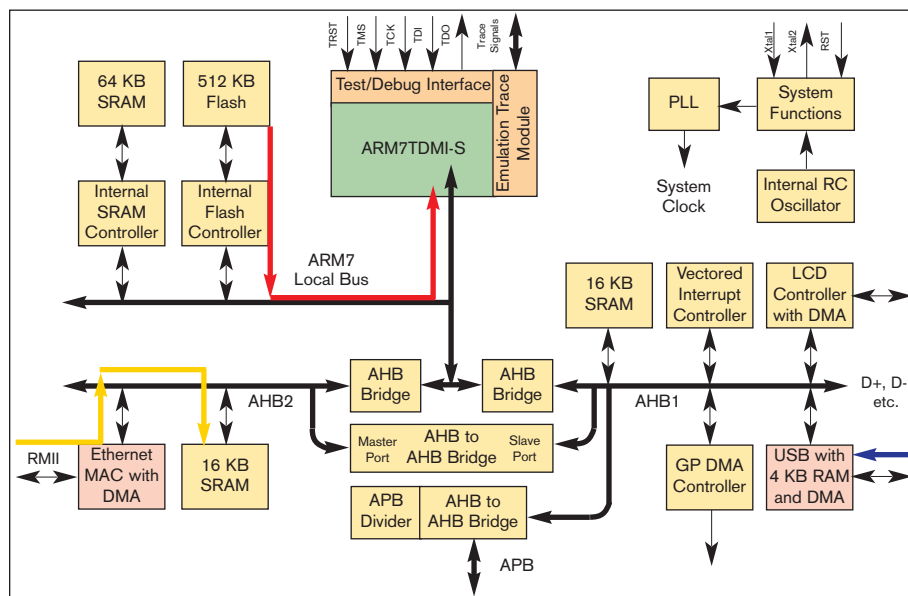

Two AHB buses with three DMA engines allow concurrent transactions for high performance





I²C LED Color Controllers

NXP Semiconductors offers a wide-variety of LED color controllers based on the I²C control bus. I²C provides easy connectivity while the integrated PWMs provide smooth color control. Drive quickly changing displays with the new PCA963x when using the fast-mode plus I²C protocol for I²C speeds up to 1 MHz and 10x the drive on the I²C bus for large networks. Set each LED to a specific brightness and dim or blink all of them with the same value. Special I²C command features optimize I²C bus commands in multi-LED control applications.

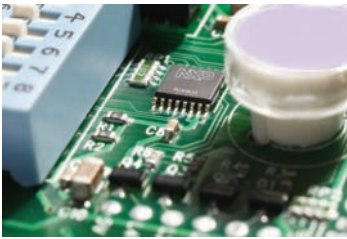

Color-mixing RGB LED drivers for mobile, entertainment, and architectural lighting

Features ▶

- I²C provides a software scalable architecture; many devices allow 126 nodes on a single bus
- Each output provides up to 25 mA of sink current and 5V tolerant outputs
- 8-bit PWMs on all devices with the PCA963x devices providing an 8-bit global PWM
- Small packages available including SO, TSSOP/MSOP, HVQFN, and HVSON
- New "sub call" command in the PCA963x devices

Benefits ▶

- Easily connects nodes in a multi-drop configuration
- High sink current, 5V tolerance is suitable for driving large transistors or constant-current sources
- 256 levels of brightness control on all devices with the PCA963x devices providing 256 levels of global brightness or blinking
- Small packages allow use in portable applications or space-constrained lighting modules
- Controls color of all devices (or four groups of devices) with a single I²C command sequence (PCA963x devices)

Applications ▶

- Architectural or landscape lighting
- Signage and gaming
- LCD backlights
- LCD or keypad backlights
- Hands-free device status indicators

Product Specifications ▶

Part Number	Type	PWM Ch. (#)/ Res. (bits)	Flash (KB)	RAM (KB)	ZigBee® Enabled (Y/N)	Core Supply (V)	IO Supply (V)	I ² C/Ch. (#)	UART/Ch. (#)	SPI/Ch. (#)	Operating Temperature (°C)	Markets
PCA9530	I ² C LED dimmer 2 outputs	2/8	-	-	N	2.3-5.5	5.5	1	-	-	-40 to +85	CL TR BL SI
PCA9531	I ² C LED dimmer 8 outputs	2/8	-	-	N	2.3-5.5	5.5	1	-	-	-40 to +85	CL TR BL SI
PCA9532	I ² C LED dimmer 16 outputs	2/8	-	-	N	2.3-5.5	5.5	1	-	-	-40 to +85	CL TR BL SI
PCA9533	I ² C LED dimmer 4 outputs	2/8	-	-	N	2.3-5.5	5.5	1	-	-	-40 to +85	CL TR BL SI
PCA9550	I ² C LED blinker 2 outputs	2/8	-	-	N	2.3-5.5	5.5	1	-	-	-40 to +85	CL TR BL SI
PCA9551	I ² C LED blinker 8 outputs	2/8	-	-	N	2.3-5.5	5.5	1	-	-	-40 to +85	CL TR BL SI
PCA9552	I ² C LED blinker 16 outputs	2/8	-	-	N	2.3-5.5	5.5	1	-	-	-40 to +85	CL TR BL SI
PCA9553	I ² C LED blinker 4 outputs	2/8	-	-	N	2.3-5.5	5.5	1	-	-	-40 to +85	CL TR BL SI
PCA9633	I ² C LED color controller-4 outputs 1 MHz fast-mode plus	4/8 + global/8	-	-	N	2.3-5.5	5.5	1	-	-	-40 to +85	CL TR BL SI
PCA9634	I ² C LED color controller-8 outputs 1 MHz fast-mode plus	8/8 + global/8	-	-	N	2.3-5.5	5.5	1	-	-	-40 to +85	CL TR BL SI
PCA9635	I ² C LED color controller-16 outputs 1 MHz fast-mode plus	16/8 + global/8	-	-	N	2.3-5.5	5.5	1	-	-	-40 to +85	CL TR BL SI

MARKETS LEGEND

CL COMMERCIAL LIGHTING FL FLASHLIGHTS TR TRANSPORTATION BL BACKLIGHTING SI SIGNAGE

Development software required

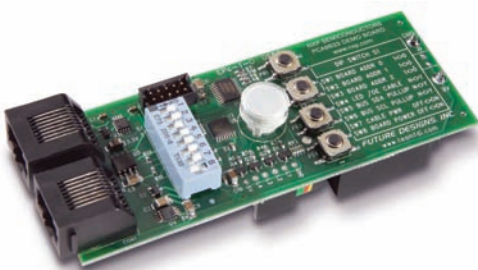

The PCA9633 demo board drives and mixes four LED colors (RGBA) to easily demonstrate networked I²C for signage and architectural lighting applications; order number OM6276

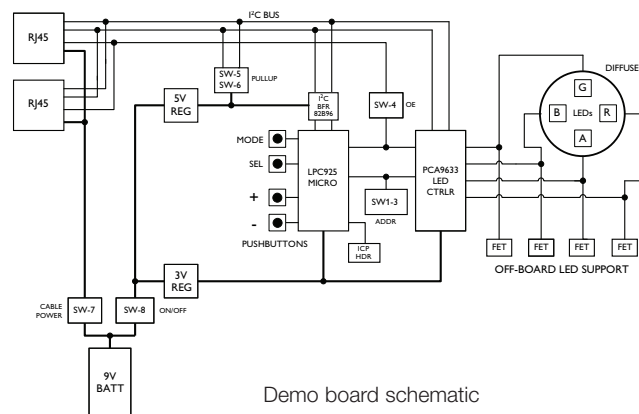

Demo board schematic