



Linear-Mode LED Drivers

Infineon Technologies' linear-mode LED driver family, BCR401, BCR402, BCR405, and newly introduced BCR450, provides efficient, low-cost constant-current solutions for LED strings from 10 mA to 700 mA. Our constant-current drivers keep light emission consistent over power supply and temperature variations, eliminate the effect of V_F variation, and help prevent thermal runaway in applications. We also offer low forward voltage Schottky diodes, including single-package reverse polarity protection diode arrays (RPP).



Ultra small 2 mm x 2.1 mm SOT343 package

Features

- Constant current adjustable from 10 mA to 60 mA, up to 500 mW power dissipation
- Current range may be extended up to 700 mA with addition of external "boost" transistor (e.g., BCX68-25)
- Selection of 18V or 40V maximum rating across driver
- On/off feature enables PWM/FM modulation
- LED-circuit protection due to negative-temperature coefficient (NTC)

Benefits

- Efficient active current regulation, accuracy of I_{OUT} at $\pm 1\%/V$ voltage variation
- Maintains consistent light emission across LED strings independent of V_F , power supply, and temperature variation
- Enables using more LEDs in one branch due to low voltage drop compared to resistor biasing schemes
- Eliminates problem of stocking multiple-bias resistor values to match incoming LED V_F bins

Applications

- Channel lighting
- Advertising signage
- Home/office lighting (recess lamps, pendant lamps, etc.)
- Rope lighting/neon replacement
- Automotive (e.g., center high-mounted stop light "CHMSL")

Product Specifications												
Part Number	Type	Dimming Type	Number of LEDs/String	Number of Strings	Configuration	Input Voltage (VDC)	Output Voltage (VDC)	Output Current (mA)	Peak Efficiency (%)	Diagnostic Capabilities	Interface	Markets
BCR401R/BCR402R	Single-output channel	PWM/FM capable on/off input	At 12V supply voltage four red or two blue LEDs	1	Series	Max. 18 across device	Linear w/ low-voltage drop	Adjustable 10-60	-	-	Discrete interface	CL TR SI
BCR401W/BCR402W		PWM/FM capable on/off input	At 12V supply voltage four red or two blue LEDs	1	Series	Max. 18 across device	Linear w/ low-voltage drop	Adjustable 10-60	-	-	Discrete interface	CL TR SI
BCR401U/BCR402U/BCR405U		PWM/FM capable on/off input	At 12V supply voltage four red or two blue LEDs	1	Series	Max. 40 across device	Linear w/ low-voltage drop	Adjustable 10-65	-	-	Discrete interface	CL TR SI
BCR450		PWM/FM capable on/off input	At 12V supply voltage four red or two blue LEDs	1	Series	Max. 27 across device	Linear w/ low-voltage drop	Adjustable 0-85	-	-	Discrete interface	CL TR SI
BCR401R + BCX68-25		PWM/FM capable on/off input	At 12V supply voltage four red or two blue LEDs	1	Series	Max. 18 across device	Linear w/ low-voltage drop	Adjustable 65-700	-	-	Discrete interface	CL TR SI
BCR450 + BCX68-25		PWM/FM capable on/off input	At 12V supply voltage four red or two blue LEDs	1	Series	Max. 27 across device	Linear w/ low-voltage drop	Adjustable 65-1,000	-	-	Discrete interface	CL TR SI

MARKETS LEGEND

CL COMMERCIAL LIGHTING FL FLASHLIGHTS TR TRANSPORTATION BL BACKLIGHTING SI SIGNAGE

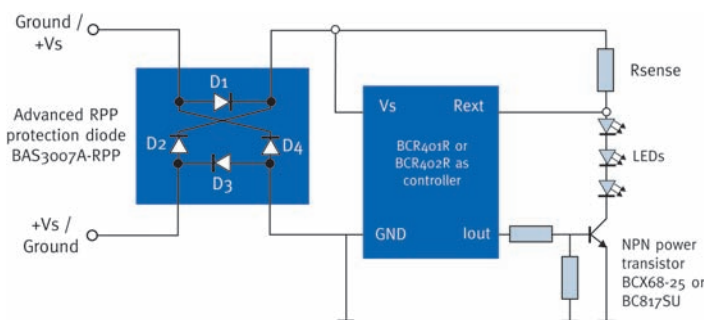

60 mA to 700 mA range LED driver with booster transistor and reverse polarity protection

*BAS3007A: If max.=700 mA, $V_F=0.38V$ (typ.) for each diode, V_{REV} max.=30V

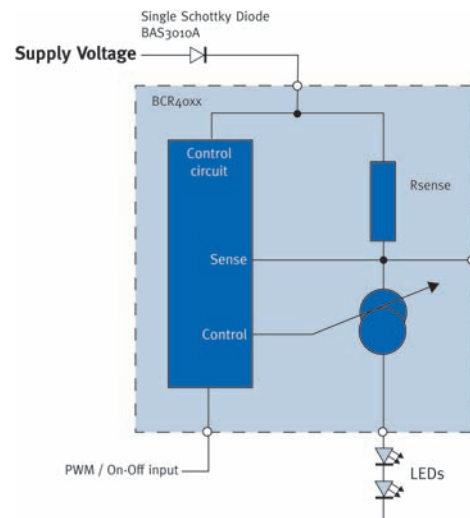

10 mA to 65 mA range stand alone LED driver with reverse polarity protection

*BAS3010A: If max.=1A, $V_F=0.38V$ (typ.), V_{REV} max.=30V

Linear Constant-Current LED Drivers

To address the increasing growth of LED usage in the automotive market, Infineon offers power supplies specifically developed for these applications.

Infineon products are designed to supply constant current to white or color LEDs up to 500 mA, independently from supply voltage or LED forward voltage class. This provides appropriate operating conditions to the connected LEDs, enabling constant brightness and ensuring extended LED lifetime.

Products with adjustable output current and PWM input enable flexible use of LEDs in applications that require brightness regulation avoiding color shift. Diagnostic capability is also offered with the open load detection feature.

Infineon LED drivers are outstanding solutions that benefit from the advantages of LEDs providing full protection to lighting applications in automotive. Connected LEDs are fully protected from short circuit, overheating, reverse polarity transients, and input voltages up to 45V.

Features ▶

- Adjustable constant-output current
- Wide input voltage range
- Over-temperature protection
- Open load detection
- Wide temperature range: -40°C to +150°C

Benefits ▶

- Efficient active current regulation, accuracy of I_{OUT} at $\pm 1\%/V$ voltage variation
- Maintains consistent light emission across LED strings independent of V_F , power supply and temperature variation
- Enables use of more LEDs in one branch due to low-voltage drop compared to resistor biasing schemes
- Eliminates problem of stocking multiple-bias resistor values to match incoming LED V_F bins

Applications ▶

- Emergency lighting
- Traffic lighting
- Architectural or concert lighting
- Automotive (interior and exterior) lighting
- Display backlighting (e.g., LCD)

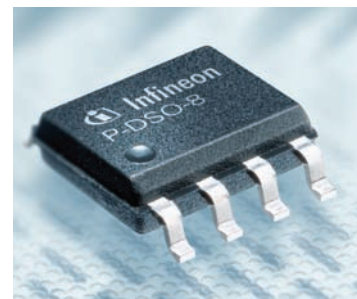

P-DSO-8, 5 mm x 6 mm

Product Specifications ▶												
Part Number	Type	Dimming Type	Number of LEDs/String	Number of Strings	Configuration	Input Voltage (VDC)	Output Voltage (VDC)	Output Current (mA)	Peak Efficiency (%)	Diagnostic Capabilities*	Interface	Markets
TLE4241	Linear	PWM	10	1	Single	Up to 45	40	70	-	TSD/TEF/OVM/LOD	PWM	CL FL TR BL SI
TLE4242		PWM	10	1	Single	Up to 45	40	500	-	TSD/TEF/OVM/LOD	PWM	CL FL TR BL SI
TLE4309		PWM	10	1	Single	Up to 45	40	500	-	TSD/OVM	PWM	CL FL TR BL SI
TLE4240-2M/3M		PWM	10	1	Single	Up to 45	6	58	-	TSD/TEF/OVM/LOD	PWM	CL FL TR BL SI

MARKETS LEGEND CL COMMERCIAL LIGHTING FL FLASHLIGHTS TR TRANSPORTATION BL BACKLIGHTING SI SIGNAGE

*Diagnostic capabilities: TSD: Thermal shutdown, TEF: Thermal error flag, OVM: Output voltage monitoring, LOD: LED open detection

