



Expertise Applied | Answers Delivered

Deliver High Reliability, Low Maintenance, and Long Term Life of LED Lighting Products

From 1W to 300W, indoor, outdoor—even highly exposed pole-mounted applications—Littelfuse offers a wide range of protection technologies that enhance LED lighting designs with solutions that minimize maintenance and warranty costs.

Varistor Products ▶

TMOV® Series

The TMOV's integrated thermal element helps facilitate TVSS module compliance, with appropriate enclosure, to UL1449 for both cord connected and permanently connected applications. The TMOV offers quick thermal response and lower inductance than most discrete solutions resulting in improved clamping performance to fast over voltage transients.



Fuse Products ▶

464 Series

Offering a miniature, fast-acting surface-mount 250V fuse, compliant with IEC Publication IEC60127-4, the 464 series was specifically designed to support power supply and lighting systems designs.



477 and 505 Series

Both designed for high energy and power supply applications: The 477 series offers 400 VDC/500 VAC rated, time-lag, surge withstand fuses offered in a miniature 5 mm x 20 mm package. The 505 series offers 500 VAC/VDC rated fuse with remarkable interrupting rating up to 50 kA in a 6.3 mm x 32 mm package.



TVS Diode Products ▶

AK6/AK10 Series

The AK6 and AK10 series are very high-current rated Transient Voltage Suppressors (TVS) designed specially to protect AC and DC line inputs from damaging transient voltages. Rated at 6 kA (8 μs x 20 μs) and 10 kA (8 μs x 20 μs) the AK series is ideal for applications intended for very harsh environments.



15KPA/30KPA Series

The 15KPA and 30KPA are high-current rated Transient Voltage Suppressors (TVS) designed to protect AC and DC input lines from damaging transient voltages. Rated at 15,000W and 30,000W respectively, these TVS are ideal to protect LED lighting applications intended for exposed environments.



1.5SMC Series

The 1.5SMC series is a Transient Voltage Suppressor (TVS) device rated at 1,500W making it ideal to protect DC-DC converters from transient voltages. The 1.5SMC series is packaged in a surface-mount DO-214AB (SMC).



Switch Mode Power Supply

LED Arrays

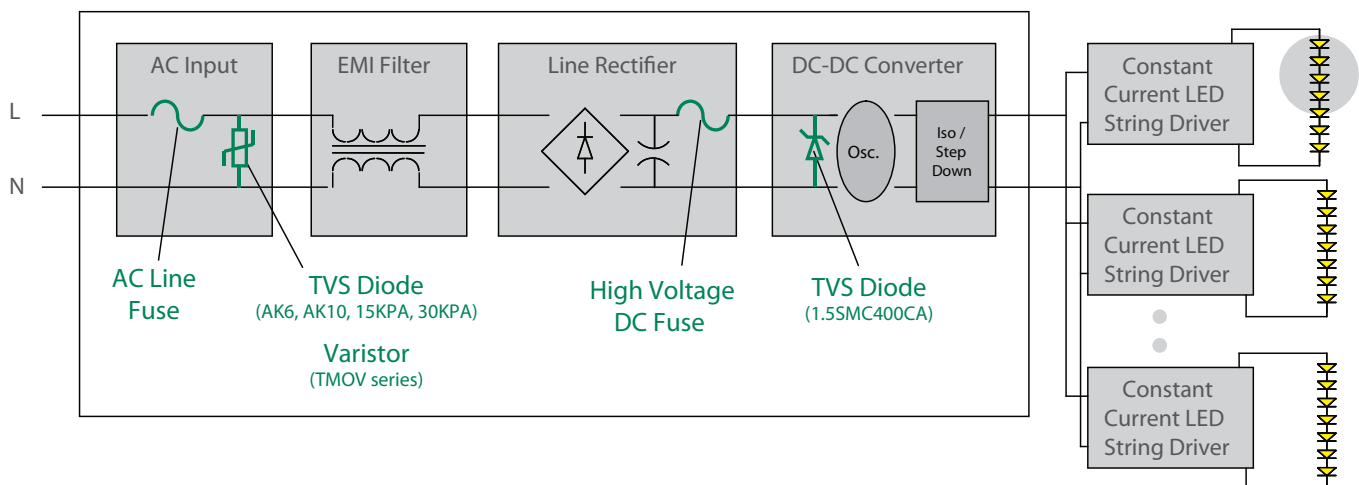

Spotlight On ▶

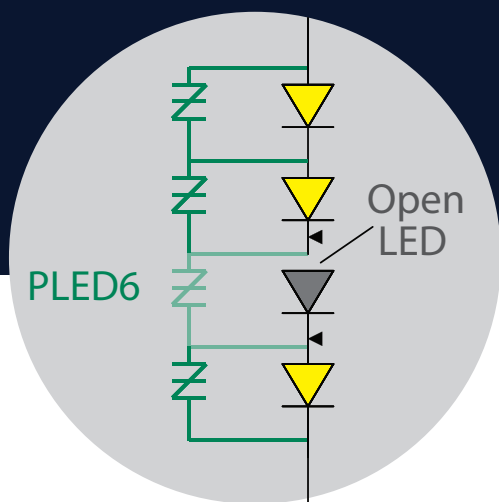

PLED

Open LED Protector Series

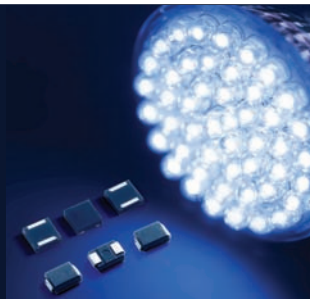

The new Littelfuse PLED series provides added reliability to LED lighting designs by minimizing the impact due to the loss of a single LED in a series string of LEDs.

The PLED provides a switching electronic shunt path that activates only when an LED goes open circuit. This shunt path bypasses the open LED and allows current to flow to the remaining LED in the string.

- Compatible with 1W, 2W, and 3W LED that have a nominal 3V forward characteristic
- Available in DO-214 AA or a chip scale QFN package
- Automatically resets after a power cycle
- Compatible with PWN dimming speeds up to 10 KHz
- Available in the following versions:
 - 6V – Ideal for placing in parallel with a single LED
 - 9V – Ideal for placing parallel with 2 LED
 - 13V – Ideal for placing in parallel with 3 LED

By minimizing the impact due to the loss of a single LED, the PLED is ideal for high reliability LED lighting destined for harsh environments.

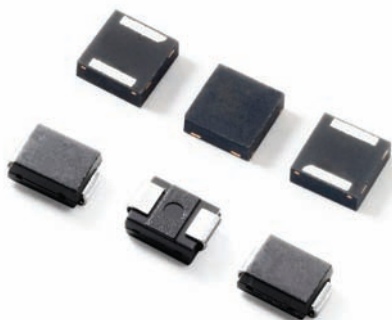

Littelfuse offers one of the broadest and deepest portfolios of circuit protection products and a global network of technical support.

Visit our design support center to access:

- | | | |
|-----------------------|---------------------------|---------------------------|
| • Reference designs | • SPICE models | • Technical articles |
| • Application notes | • Local technical support | • Certification documents |
| • Application testing | • Product samples | • Data sheets |

Visit lighting.arrow.com/designtools to access design tools including the Littelfuse design support center.

Panasonic

Panasonic Electric Works



NaPiOn sensors are used in various energy-saving applications including lighting equipment

Fully Integrated Miniature Motion Sensor Detects Human Infrared Radiation

The NaPiOn motion sensor from Panasonic Electric Works is a passive infrared (PIR) type sensor specially designed to detect human body infrared radiation. All necessary components are combined into a package that is less than 10 mm in diameter. Environmentally safe and energy efficient, the NaPiOn motion sensor offers these outstanding features:

- Fully integrated assembly
- Built-in amplifier and multi-surface lens construction
- Miniature size: 9.5 mm in diameter and 14.5 mm in height
- Excellent noise withstanding capability
- Digital and analog output available
- Dual lens colors (black and white) for design flexibility
- Low power consumption available operating on a 3V power supply

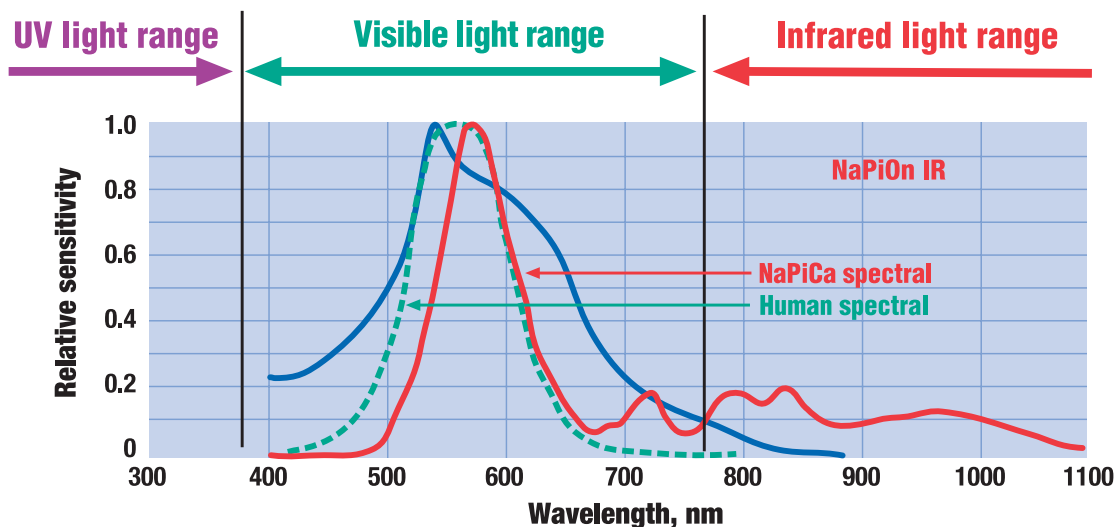
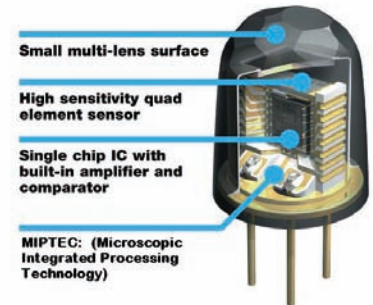

Cadmium-Free Light Sensor with Built-In Optical Filter

Applications for the NaPiCa include brightness detection for circuits in household lighting, crime prevention lighting, automatic lighting for vending machines, and LCD backlight control.

The NaPiCa light sensor has spectral response similar to that of the human eye. Cd-free and Pd-free, the NaPiCa comes with a built-in photocurrent amplifier in a miniature SMD package—1.0 mm (L) x 3.2 mm (W) x 1.0 mm (H). All that and these features:

- Linear photo current output
- Operates on 1.5 VDC to 6 VDC, suitable for battery operation
- Uses environmentally friendly silicon chips



Thru-hole and SMD types available

Arrow Electronics Lighting Group

1.888.9LIGHT1

<http://lighting.arrow.com>

Narrow-Pitch P5 Series Connectors— for Board-to-Board Connection

Panasonic

Panasonic Electric Works

This series of connectors offers strong resistance to adverse environments and high-contact reliability due to Panasonic's unique "tough contact" construction.

- Tough against dropping: bellows contact construction increases resistance to shock of dropping
- Tough against foreign particles and flux: V-notch improves contact reliability
- Tough against solder rise due to Ni barrier construction
- Tough against corrosive gases because of porosity treatment
- P5KF—two-piece structure and 0.5 mm pitch; mated height of 1.5 mm, 2.0 mm, and 2.5 mm
- Simple locking structure; superior mating operation with click feel to indicate that mating is complete
- P5K—0.5 mm pitch; mated height of 3.0 mm and 3.5 mm
- P5KS—0.5 mm pitch; mated height of 4.0 mm, 4.5 mm, 5.0 mm, 5.5 mm, 6.0 mm, 6.5 mm, 7.0 mm, 8.0 mm, and 9.0 mm

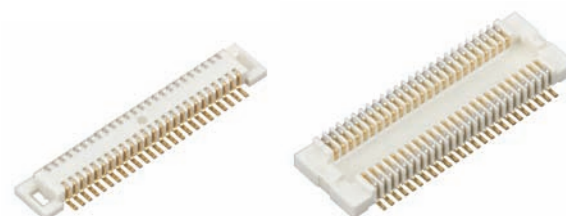

P5KF header and socket



P5K header and socket



P5KS header and socket



F4S header and socket

Narrow-Pitch F4S Series Connectors— for Board-to-FPC Connection

The F4S series of connectors offers strong resistance to adverse environments and high-contact reliability due to Panasonic's unique "tough contact" construction.

- Tough against dropping: bellows contact construction increases resistance to shock of dropping
- Tough against foreign particles and flux: V-notch improves contact reliability
- Tough against solder rise due to Ni barrier construction
- Tough against corrosive gases because of porosity treatment
- Low-profile 0.4 mm pitch connectors that form a board-to-FPC connection with 1.0 mm and 1.2 mm mated height
- Space-saving 3.6 mm width
- Simple lock structure gives tactile feedback that ensures a superior mating/unmating operation feel
- Gull-wing terminals facilitate automatic mounting inspections



Wire-to-Board Hermaphroditic Blade and Receptacle Connector Simplifies PCB Layout

Tyco Electronics' wire-to-board hermaphroditic blade and receptacle connector brings power leads attachment to a string of aluminum-clad printed circuit boards used for LED strings, lighting controls, and LED modules as well as conventional glass-epoxy printed circuit boards populated with the hermaphroditic board-to-board connectors. The wire-to-board connector is available in two, four, and six positions with a 6A, 125 VAC/125 VDC rating on 18-22 AWG stranded wire. The latest version of the board-to-board connectors has a side embossment latching feature that accepts the latch from the wire-to-board connector. Therefore, customers can now manufacture a single board layout per application rather than creating two separate boards with different power connections. A dust cover connector is also available to enclose the last hermaphroditic connector in a string of boards.

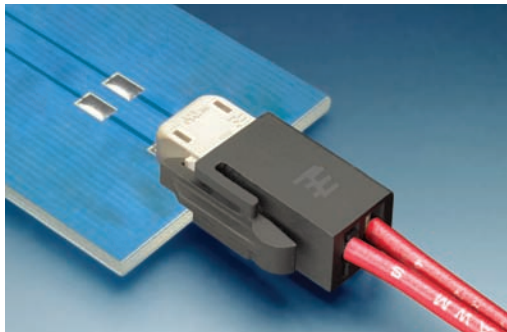

Next Generation SMT and Thru-Hole Poke-In Wire Expands Product Offering for LED String Application

Tyco Electronics' SMT and thru-hole poke-in wire connectors provide a low-profile, quick, and reliable labor saving termination alternative to hand soldering wires to single-sided, aluminum clad PCB-based LED strings, lighting controls, and other non-lighting FR4 PCB applications. The connectors accept 18-22 AWG solid wire; 18-20 AWG pre-bond wire, and 18 AWG stranded wire (16 strands maximum) and are rated for 5A with a 250 VAC/250 VDC voltage rating (4A on 22 AWG wire). They are available in one or two positions, with single-position connectors offered in white or black for easy polarity identification. The standard- and low-insertion-force (recommended for 18 AWG stranded wire) versions of the connectors are side-to-side stackable on 4 mm centers. Gel-filled versions are available for indoor or outdoor application where moisture is an issue. The poke-in wire LED connectors are available in tape-and-reel packaging for high-speed SMT and thru-hole processing equipment. Housings are made of high-temperature plastic that is reflow solder process compatible.

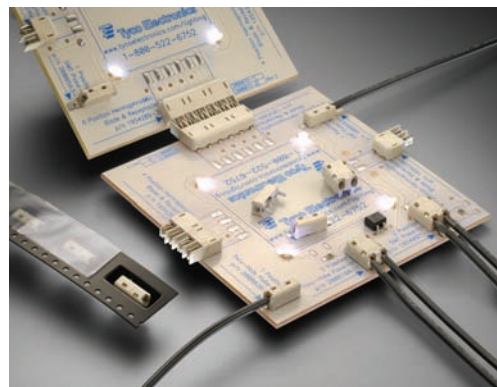

TE logo and Tyco Electronics are trademarks.

Arrow Electronics Lighting Group

1.888.9LIGHT1

<http://lighting.arrow.com>

Inverted SMT Thru-Board Connectors Allow Power from Underside of Boards—Speeds LED Assembly

The Tyco Electronics inverted SMT thru-board connector provides a means to bring power from the underside of an aluminum-clad or FR4 PC board, thus eliminating dressing wire leads on the top side of LED boards. With a space-saving, low-profile design and rounded corners to minimize shadowing, the two- through six-position connectors fit through a hole or notch in the board to present an underside interface. The connector accepts the standard Tyco Electronics Mini CT connectors and uses surface-mount hold-downs to provide stability during mating and unmating. The inverted design facilitates easier assembly and installation of solid-state LED lighting in architectural, residential, and commercial applications. The Mini CT connector is rated for 3A per contact on 24 AWG wire. High-temperature materials allow the connector to be reflow soldered, while a flat top surface provides compatibility with vacuum pickup. With UL Listing and CSA Certification, the connectors meet the requirements of UL 1977, File No. E2847

 **Tyco Electronics**
Authorized Distributor

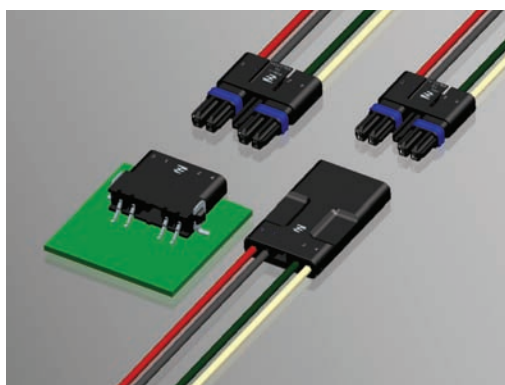
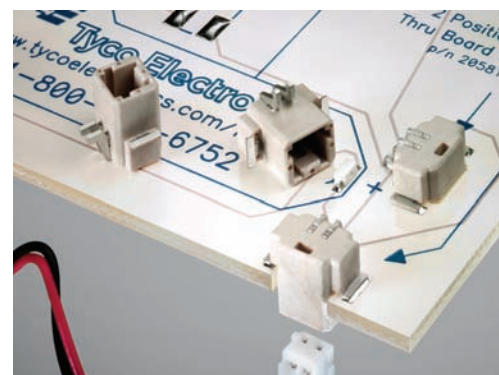

Sealed Lighting Connector for Outdoor Applications

Tyco Electronics' low-profile sealed lighting connector is designed specifically for outdoor lighting applications. The product family is available in two through four positions in wire-to-wire and wire-to-board styles—including vertical- and right-angle headers in SMT and thru-hole configurations. The connectors accept 18-26 AWG wire and have a 5A, 120 VAC rating with an operating temperature of -40 degrees Celsius to +105 degrees Celsius. They are manufactured using UV-resistant material with an IP67 seal rating. The polarized connectors have positive latching and a long grounding pin option for make-first/break-last capability. The connectors are shipped fully assembled with interfacial seals, rear seals, and wire guide in place ready to accept crimp-snap terminals.

Choose 7.5 mm MiniHVL When Size and Easy Interconnection is Required

Tyco Electronics' 7.5 mm MiniHVL connector system is suitable for power connection and coupling between lamps and fixtures in offices, kitchens, bathrooms, shops, household furniture, display cabinets, and mountable lighting. Designed according to the IEC 60320 standard for lighting industry applications, this system is ideal when size and easy interconnection are key requirements. Installable in small fixtures, the connector system is available in wire-to-wire configuration, offering outlet and plug assemblies with two contact positions. Using widely adopted MQS contacts, it provides a six-way distributor connector with an additional switch feature. The switch version is available using an additional seventh way and specially-coded red plug for external switch input. Applications include general two-pole appliance wiring system for household and similar purposes from low voltage up to 250V. An outlet bridge, splitter, panel-mount outlet, and bus-bar splitter expands interconnection options.



7.5 mm MiniHVL, TE logo, and Tyco Electronics are trademarks.

Arrow Electronics Lighting Group

1.888.9LIGHT1

<http://lighting.arrow.com>